

Dexion Strata 2 Planters



Product overview

Dexion Strata 2 Planters are a premium range of cabinet planter boxes designed to be used on top of Dexion Strata 2 Tambour Door, Swing Door, Sliding Door, Lateral Drawer and Bookcase cabinets.

Dexion Strata 2 Planters are available with both plain and perforated fronts. Perforated planters come complete with sound absorbing acoustic panels as standard.

The planters consist of three nested components: a powdercoated steel tray with adjustable pot openings, waterproof ABS liner and powdercoated steel carcass.

The planter boxes are available with optional full depth moulded ABS liners that provide both strong support and moisture protection for which are not self contained. The Dexion Strata 2 Planters are designed to accept 200mm (8") pots as standard, with a maximum aperture of 230mm (9").

Key features and benefits

- Planters are provided as a complete assembled unit.
- Pre-fitted clear rubber feet are secured to the underside of the planter box. Feet assist in holding the planter in position whilst on the cabinet and prevent any scuffing of the cabinet top.
- Plain or perforated designs available.
- Sound absorbing acoustic panels fitted as standard to perforated planter design.
- Environmentally sustainable waterproof ABS full depth safety liner (optional)
- Unique top tray with folding tabs to assist in retaining fill. It can also be inverted for use without any fill.
- GECA certified.

Dexion Strata 2 Planters

| Accessory Type | Height | Width | Depth | Number of 200mm Pots | Colour | Code | S/MTO |
|----------------|--------|--------|---------------------|----------------------|--------|--------|-------|
| Plain | 230mm | 900mm | 460mm | 3 x 200mm | WS | 176912 | S |
| Plain | 230mm | 1050mm | 460mm | 3 x 200mm | WS | 176911 | S |
| Plain | 230mm | 1200mm | 460mm | 4 x 200mm | WS | 176910 | S |
| Plain | 230mm | 1600mm | 460mm | 5 x 200mm | WS | 176936 | MTO |
| Plain | 230mm | 1800mm | 460mm | 6 x 200mm | WS | 176937 | MTO |
| Plain | 230mm | 2000mm | 460mm <td 6 x 200mm | WS | 176938 | MTO | |
| Perforated | 230mm | 900mm | 460mm | 3 x 200mm | WS | 176919 | S |
| Perforated | 230mm | 1050mm | 460mm | 3 x 200mm | WS | 176923 | S |
| Perforated | 230mm | 1200mm | 460mm | 4 x 200mm | WS | 176918 | S |
| Perforated | 230mm | 1600mm | 460mm | 5 x 200mm | WS | 176940 | MTO |
| Perforated | 230mm | 1800mm | 460mm | 6 x 200mm | WS | 176941 | MTO |
| Perforated | 230mm | 2000mm | 460mm | 6 x 200mm | WS | 176942 | MTO |

Key: – UDL: Uniformly distributed load, WS: White Satin, S = Stocked, MTO: Made to Order

Component details

Dexion Strata 2 Planters are comprised of the following components:

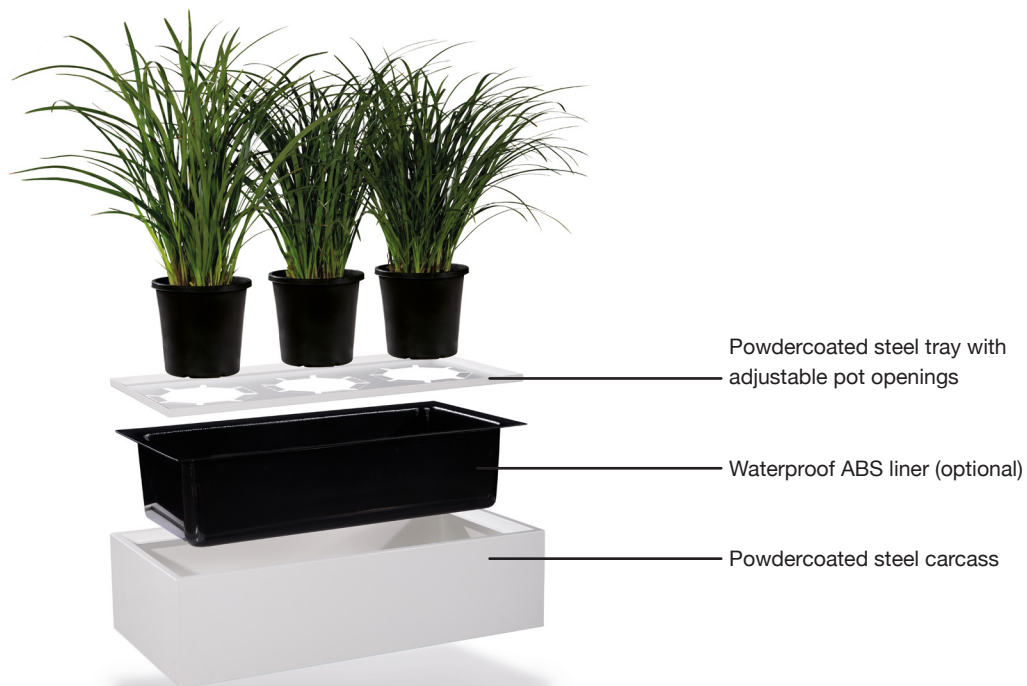

Dexion Strata 2 Planters

Planter sizes

Strata 2 Planters are supplied as a complete assembled unit. The diagram below denotes the number of pots each planter size can accommodate.

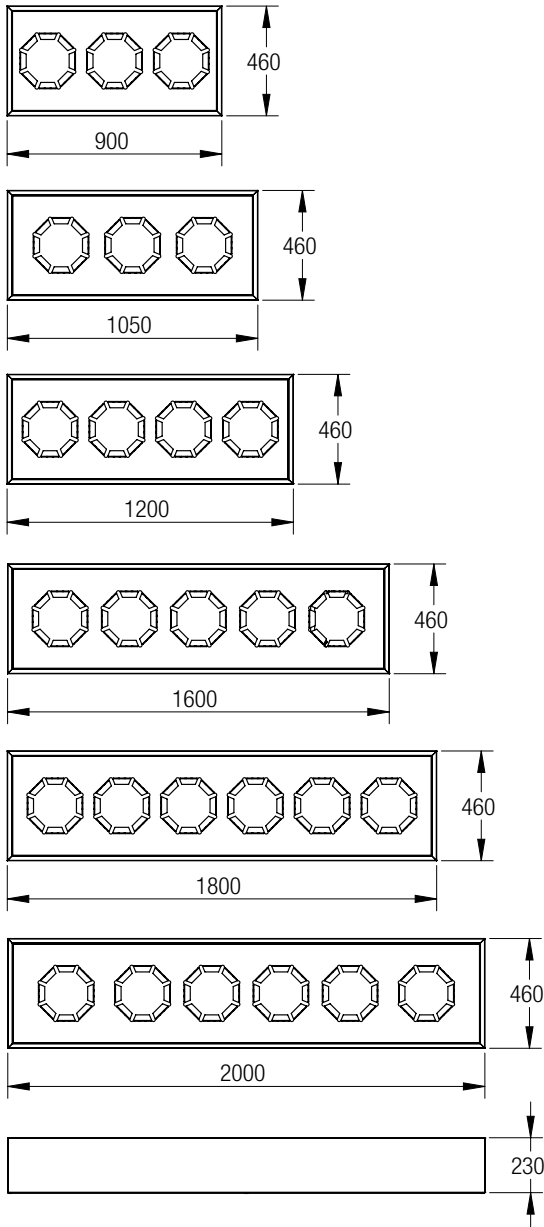

Planter integration

Dexion Strata 2 Planter boxes are designed specifically for integration with the Strata 2 cabinet range. Planter boxes and cabinets are designed to align with standard heights in the cabinet range producing clean, consistent lines.

Please note: the recommended maximum height combination should not exceed 1430mm. The maximum height is achieved by using a 1200mm high cabinet with a standard 230mm planter box. Planter boxes accept 200mm diameter pots.

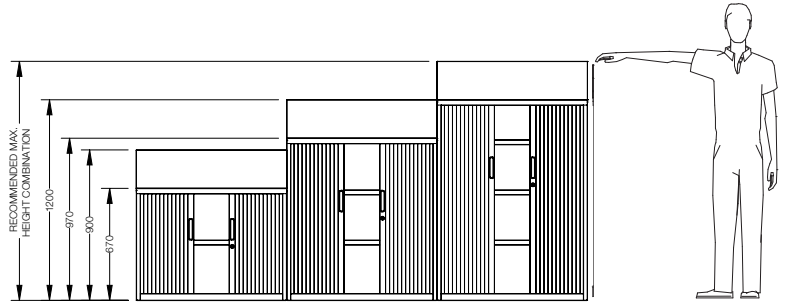

Contact

For more information on the Dexion Strata 2 Planters, please contact us on 1300 180 358.

Disclaimer:

The Information contained herein is the intellectual property of Dexion. The Information is defined to include: data, text, images, specification, graphics, design details and any and all other information whatsoever contained herein. The Information has been produced exclusively for Dexion and may not be used for any other purpose. None of the information may be used, altered, edited, copied, distributed or duplicated in any way without the express written consent of Dexion. Whilst the utmost care is taken to ensure the accuracy of the information contained herein, Dexion makes no guarantee as to its accuracy. Dexion shall, under no circumstances, be liable for any costs, losses, expenses or damages which may in any way be attributable to the use or adoption of such data and/or design details. All dimensions indicated are nominal only. Dexion reserves the right to alter or amend any of the information herein, including data and design details, without prior notice.